

- Full Duplex Encode / Decode Capability
- Compatible with Model 1000 Digital Audio Processor Chassis
- Quick Recovery from Transmission Errors
- Toll Quality Speech at 32 Kbps
- ADPCM Audio Compression
- Meets CCITT recommendation G.712
- MIL-STD-188-114 Serial Digital Interface
- Software Re-configurable Encoding

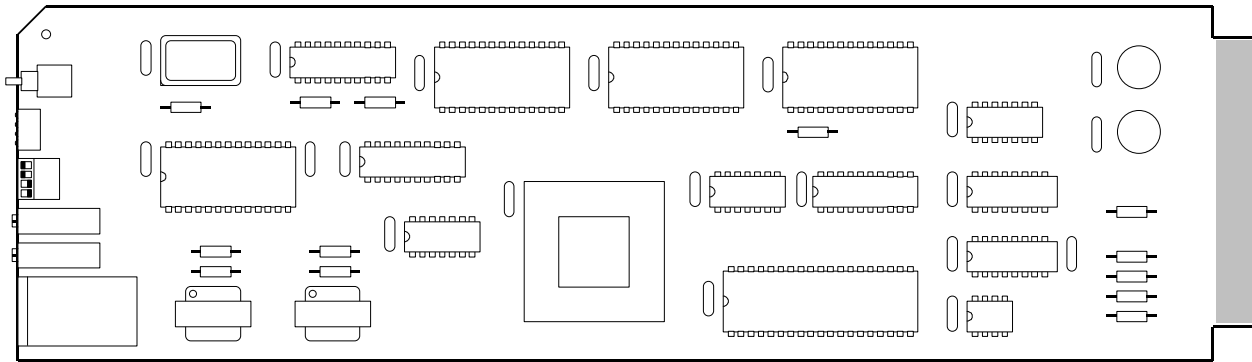

MODEL 1012 Universal Channel Card

The Model 1012 Universal Channel Card permits very efficient and high quality transfer of analog audio information over a long haul digital communications link. The Universal Channel Card utilizes microprocessor technology and high speed digital signal processing for real time Adaptive Differential Pulse Code Modulation (ADPCM) encoding and decoding of analog audio signals.

Incorporation of the CCITT standard ADPCM encoding results in digital compression of audio signals that reduce the required digital bandwidth to less than half of that required for conventional 64 Kbps PCM digitization techniques. This ADPCM encoding provides toll quality audio fidelity as well as supporting high speed modem signals. Other encoding algorithms to include CELP, LPC, and PCM are all adaptable for operation on the Universal Channel Card.

The flexible design of the Universal Channel Card provides a standard hardware platform for incorporation of a multitude of audio compression algorithms. Designed around the Analog Devices ADSP-2111 high speed Digital Signal Processor, the card is easily software re-configurable as future system requirements necessitate. Programmable on board phase locked oscillator and USART circuitry ensures present and future compatibility with any digital data format to include fractional T1 and ISDN digital networks.

The Universal Channel Card is designed to operate in either the dual channel Model 1020 Channel Card Chassis or operate in the eight channel Model 1000 Digital Audio Processor Chassis. This card is intended as a universal form, fit, and function replacement for the Model 1000 ADPCM Channel Card.

## Analog Characteristics

### Audio Inputs:

Quantity	one
Impedance	600 ohm, balanced
Level (adjustable)	0 dBm $\pm$ 15 dB

### Audio Outputs:

Quantity	one
Impedance	600 ohm, balanced
Level (adjustable)	0 dBm $\pm$ 15 dB

## Digital Characteristics

### Data Inputs:

Quantity	one
Interface	MIL-STD-188-114A synchronous, balanced
Data Rate	synchronous with clock 32 Kbps maximum

### Data Outputs:

Quantity	one
Interface	MIL-STD-188-114A synchronous, balanced
Data Rate	synchronous with clock 32 Kbps, max.

## Operational Characteristics

### Path Characteristics:

Frequency Response	300 to 3400 Hz
Gain Variation	$\pm$ 1 dB over frequency

## General Characteristics

### Temperature:

Operating	0 <sup>o</sup> to +50 <sup>o</sup> C
Storage	-30 <sup>o</sup> to +75 <sup>o</sup> C

### Humidity:

Operating	0 to 90%, non-condensing
Storage	0 to 90%, non-condensing

### Altitude:

Operating	15,000 feet maximum
Storage	15,000 feet maximum

### Power:

Voltage	$\pm$ 5, $\pm$ 12 VDC
---------	-----------------------

### Mechanical:

Size	3.57" x 12.00"
------	----------------

### Ordering Information:

Part Number	AS1012001
-------------	-----------

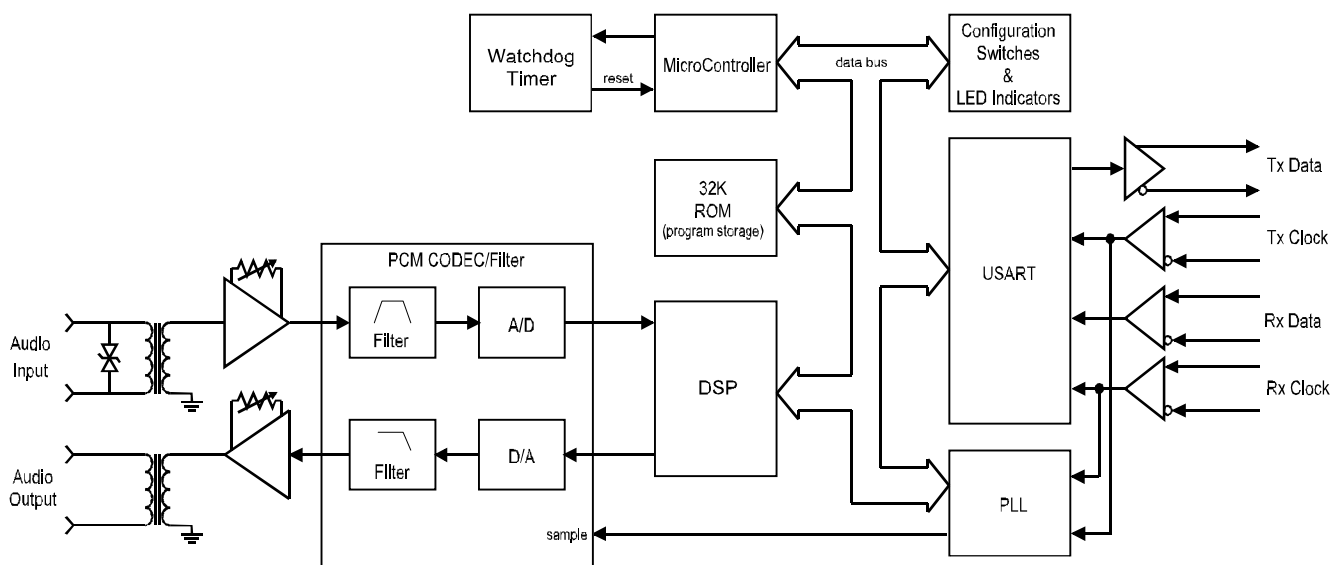

Block Diagram